

SPE10S60H-A

主要参数 MAIN CHARACTERISTICS

600V/10A 3相全桥驱动	
V_{CES}	600V
I_C	10A
V_{ISO}	2000V

用途

- 风机
- 水泵
- 冰箱

APPLICATIONS

- Fan motor
- Water pump
- Refrigerator

产品特性

- 600V/10A 三相逆变器，内置低损耗沟道栅-场截止型 IGBT。
- 信号高电平有效，兼容 3.3V 和 5V 的 MCU。
- 内置自举二极管
- 内置欠压保护、过流保护、过温保护。
- 使能关断功能
- 负温度系数 NTC 温度检测输出

FEATURES

- 600V/6A three-phase inverter with built-in low-loss trench gate-field stop IGBT.
- Signal high level valid, compatible with 3.3v and 5V MCU.
- Built-in bootstrap diode.
- Built-in undervoltage protection、Over current protection、Over temperature protection.
- Shut-Down Input
- Negative temperature coefficient thermistor detection output.

封装 Package

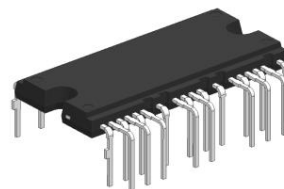

DIP26-FP

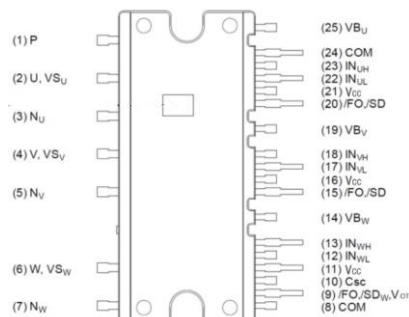

PIN1-PIN25

订货信息 ORDER MESSAGE

订货料号 Order number	产品信息 Product information			
	无卤-条管 Halogen-Free-Tube	无卤-编带 Halogen-Free-Reel	印记 Marking	封装 Package
2A01-0645-16	SPE10S60H-A	N/A	SPE10S60H-A	DIP26-FP

模块分布示意图 Module distribution diagram



图 1：模块内部电路示意图

Fig 1: Internal circuit

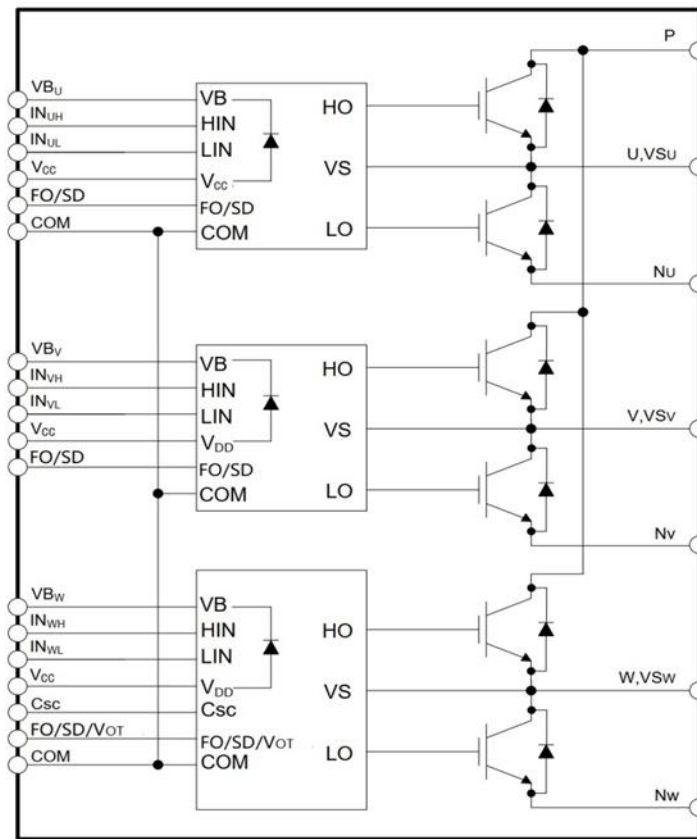

图 2：模块引脚分布示意图

Fig 2: Distribution of pin

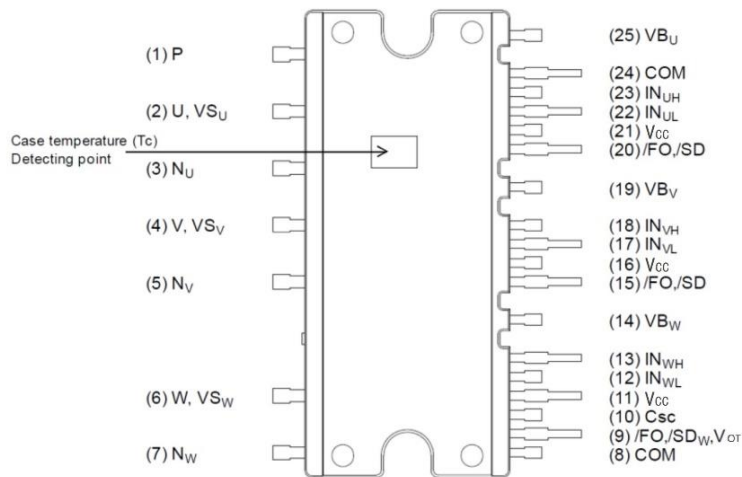

引脚编号 Number	引脚名称 Name	引脚描述 Description
1	P	逆变器直流输入端子 Dc input terminal of inverter
2	U, VS _U	U 相输出和 U 相高侧驱动偏置电压地 Output for U-Phase & Bias Voltage Ground for U-phase High-Side Driving
3	N _U	U 相下臂 IGBT 发射极端子 U phase lower arm IGBT emitter terminal
4	V, VS _V	V 相输出和 V 相高侧驱动偏置电压地 Output for V-Phase & Bias Voltage Ground for V-phase High-Side Driving
5	N _V	V 相下臂 IGBT 发射极端子 V phase lower arm IGBT emitter terminal
6	W, VS _W	W 相输出和 W 相高侧驱动偏置电压地 Output for W-Phase & Bias Voltage Ground for W-phase High-Side Driving
7	N _W	W 相下臂 IGBT 发射极端子 W phase lower arm IGBT emitter terminal
8	COM	公共电源接地 GND Common Supply Ground
9	/FO, /SD _W , VOT	故障输出, W 相输入关闭, 温度输出 Fault Output, Shut-Down Input for W Phase, Temperature Output
10	CSC	过流和短路保护关闭输入端子 Shut Down Input for Over Current and Short Circuit Protection
11	V _{CC}	控制电源端子 Control power terminal
12	IN _{WL}	W 相下臂控制信号输入端子 W phase lower arm control signal input terminal
13	IN _{WH}	W 相上臂控制信号输入端子 W phase upper arm control signal input terminal
14	VB _W	W 相上臂驱动电源端子 W phase upper arm drive power terminal
15	/FO/SD _V	V 相输入关闭 Shut-Down Input for V Phase
16	V _{CC}	控制电源端子 Control power terminal
17	IN _{VL}	V 相下臂控制信号输入端子 V phase lower arm control signal input terminal
18	IN _{VH}	V 相上臂控制信号输入端子 V phase upper arm control signal input terminal
19	VB _V	V 相上臂驱动电源端子 V phase upper arm drive power terminal
20	/FO/SD _U	U 相输入关闭 Shut-Down Input for U Phase
21	V _{CC}	控制电源端子 Control power terminal
22	IN _{UL}	U 相下臂控制信号输入端子 U-phase lower arm control signal input terminal
23	IN _{UH}	U 相上臂控制信号输入端子 U-phase upper arm control signal input terminal
24	COM	公共电源接地 GND Common Supply Ground
25	VB _U	U 相上臂驱动电源端子 U-phase upper arm drive power terminal

图 3: 模块引脚功能定义表

Fig 3: Pin function

最大额定值 (T_j= 25°C, 除非特殊说明)Absolute Maximum Ratings (T_j= 25°C, Unless otherwise Specified)

逆变部分 Inverter Part

记号 Symbol	参数 Parameter	条件 Condition	额定值 Ratings	单位 Units
V _{PN}	电源电压 Power supply voltage	应用于 P- NU, NV, NW 之间 Applied between P- NU, NV, NW	450	V
V _{PN(Surge)}	电源电压 (含浪涌) Power supply voltage (including surge)	应用于 P- NU, NV, NW 之间 Applied between P- NU, NV, NW	500	V
V _{CES}	集电极-发射极之间电压 Collector emitter Voltage of Each IGBT		600	V
±I _c	集电极电流 Each IGBT Current, Continuous	T _c = 25° C,	10	A
±I _{CP}	集电极电流 (峰值) Each IGBT Pulse Current, Peak	T _c = 25° C, 脉冲宽度小于 1ms TC=25°C, Less than 1mS	20	A
P _c	集电极功耗 Maximum Power Dissipation	T _c = 25° C, 单晶片 T _c = 25°C, Each IGBT	26	W
T _j	结温 Junction Temperature	(见备注 1) Note1	-40~150	° C

控制部分 Control Part

记号 Symbol	参数 Parameter	条件 Condition	额定值 Ratings	单位 Units
V _{CC}	控制电源电压 Control Supply Voltage	V _{CC} -COM 之间 Applied between V _{CC} and COM	20	V
V _{BS}	高侧控制电压 High-side Bias Voltage	VB-V _S 之间 Applied between VB and V _S	20	V
V _{IN}	输入信号电压 Input Signal Voltage	V _{IN} -COM 之间 Applied between V _{IN} and COM	-0.3~V _{CC} +0.3	V

整个系统 Total System

记号 Symbol	参数 Parameter	条件 Condition	额定值 Ratings	单位 Units
V _{PN(PROT)}	自我保护电源电压限制 Self-protecting power supply voltage limit	V _{CC} =V _{BS} =13.5V~16.5V, T _j =125° C, 非重复性, <2us	400	V
T _c	模块壳体工作温度 Module shell temperature		-20~100	°C
T _{STG}	贮存温度 Storage Temperature	T _c =25°C	-40~125	°C
V _{ISO}	绝缘耐压 Isolation Voltage	60Hz, 正弦, AC 1 分钟, 连接管脚到散热器 60Hz, Sinusoidal, AC 1 min, between pins and heat-sink plate	2000	V

备注 1: IPM 功率晶片最大额定结温为 150° C (@表面温度 T_c ≤ 100° C)。然而, 为了确保 IPM 运行安全, 结温应限定于 T_{j(av)} ≤ 125° C (@表面温度 T_c ≤ 100° C)。



Note 1: The maximum rated junction temperature of the IPM power chip is 150° C (@surface temperature TC ≤ 100° C). However, to ensure safe operation of the IPM, the junction temperature should be limited to Tj(av) ≤ 125° C (@surface temperature TC ≤ 100° C)

热阻 Thermal Resistance

记号 Symbol	参数 Parameter	条件 Condition	额定值 Ratings	单位 Units
Rth(j-c)Q	结到外壳的热阻 Junction to Case Thermal resistance	逆变器工作条件下的单个IGBT Each IGBT	4.8	°C/W
Rth(j-c)F	结到外壳的热阻 Junction to Case Thermal resistance	逆变器工作条件下的单个FRD Each FRD	6.0	°C/W

备注 2: 关于壳体温度 (TC) 的测量点, 参见图 2。

Note 2: For the measurement point of shell temperature (TC), see Figure 2.

电气特性 (Tj=25°C, 除非特别说明)

Electrical Characteristics (Tj=25°C, Unless Otherwise Specified)

逆变部分 Inverter Part

记号 Symbol	参数 Parameter	条件 Condition	最小值 Min.	典型值 Typ.	最大值 Max.	单位 Unit	
V _{CE(SAT)}	集电极-发射极间饱和电压 Collector - emitter saturation voltage	V _D =V _{DB} =15V, V _{IN} =5V	I _C =10A, T _J =25° C,	-	1.7	2.3	V
			I _C =10A, T _J =125° C,	-	2.0	-	
V _F	FRD正向电压 FRD Forward voltage	V _{IN} = 0V, I _C =-10A,	-	1.6	2.2	V	
I _{CES}	集电极-发射极间漏电流 Collector emitter leakage current	V _{CE} =V _{CES}	-	-	250	uA	
t _{ON}	开关时间 (备注3) Switching Times(Note 3)	V _{PN} = 300 V, V _D = V _{DB} = 15 V, I _C =10 A V _{IN} = 0 V ↔ 5 V, 电感负载 / Inductive Load	-	600	-	nS	
t _{C(ON)}			-	200	-		
t _{OFF}			-	650	-		
t _{C(OFF)}			-	90	-		
t _{TR}			-	130	-		

备注 3: t_{ON} 和 t_{OFF} 包括驱动 IC 内部传输延迟时间。t_{C(ON)} 和 t_{C(OFF)} 是 IGBT 自身被内部给定门极驱动条件下的开关时间。详见图 3。

Note 3: t_{ON} and t_{OFF} include the internal transmission delay time of the driver IC. t_{C(ON)} and t_{C(OFF)} are the switching times of the IGBT itself driven by the internally given gate. See Figure 3 for details.



控制部分 Control Part

记号 Symbol	参数 Parameter	条件 Condition		最小值 Min.	典型值 Typ.	最大值 Max.	单位 Unit
I _{QCC}	V _{CC} 静态电流 Quiescent V _{CC} Supply Current	V _{CC} =15V V _{IN} =0V	V _{CC} -COM 之间 Applied between V _{CC} and COM	-	-	1500	uA
I _{QBS}	V _{BS} 静态电流 Quiescent V _{BS} Supply Current	V _{BS} =15V V _{IN} =0V	VB(U)-U, VB(V)-V, VB(W)-W 之间 Applied between VB(U)-U, VB(V)-V, VB(W)-W	-	-	200	uA
V _{FOH}	故障输出电压 Fault Output Voltage	V _{SC} =0V, /FO 上拉 6.8KΩ 电阻到 5V V _{SC} =0V, /FO 6.8KΩ to 5V Pull-up		4.6	-	-	V
V _{FOL}	故障输出电压 Fault Output Voltage	V _{SC} =1V, /FO 上拉 6.8KΩ 电阻到 5V V _{SC} =1V, /FO: 6.8KΩ to 5V Pull-up		-	-	0.5	V
V _{SC(ref)}	短路跳闸阈值 Short-Circuit Trip Level	V _{CC} =15 V		0.45	0.5	0.55	V
UV _{CCD}	低侧欠压保护 (图 5) Low-Side Under-Voltage Protection (Fig 5)	检测电平 Detection Level		9	10.5	12	V
UV _{CCR}		复位电平 Reset Level		10.5	11	12.5	V
UV _{BSD}	高侧欠压保护 (图 6) High-Side Under-Voltage Protection (Fig 6)	检测电平 Detection Level		9	10.5	12	V
UV _{BSR}		复位电平 Reset Level		10.5	11	12.5	V
T _{FO}	故障输出脉冲宽度 Fault-Out Pulse Width			20	-	-	uS
V _{OT}	温度检测输出 Temperature Sensing Voltage Output (note4)	T _c =90°C, 上拉电阻 6.8KΩ 到 5V, CSC=0V		-	2.89	-	V
		T _c =25°C, 上拉电阻 6.8KΩ 到 5V, CSC=0V		-	4.68	-	V
T _{OTP}	过温度保护阈值 Over temperature protection threshold			-	150	-	°C
V _{FSDR}	使能关断复位电平 Shut-down Reset level	SDx-COM		-	2.3	-	V
V _{FSDD}	使能关断阈值电压 Shut-down Detection level	SDx-COM		-	1.5	-	V
V _{IH}	导通阈值电压 ON Threshold Voltage	逻辑高电平 Logic high level	施加在V _{IN} 和COM之间 Applied between Vin-COM	-	2.3	-	V
V _{IL}	关断阈值电压 OFF Threshold Voltage	逻辑低电平 Logic low level		-	1.5	-	V

备注 4: IPM 的 VOT 输出特性曲线请参考图 4.2, 图 4.2 曲线是以 6.8KΩ 上拉电阻至 5V 和以 4.7 KΩ 上拉电阻至 3.3V 测试结果。

Note 4: Please refer to figure 4.2 for the VOT output characteristic curve of IPM. The curve in Figure 4.2 shows the test results of 6.8 KΩ pull-up resistance to 5V and 4.7 KΩ pull-up resistance to 3.3V.



推荐工作条件 Recommended Operating Conditions

记号 Symbol	参数 Parameter	条件 Condition	最小值 Min.	典型值 Typ.	最大值 Max.	单位 Unit
V_{PN}	电源电压 Supply Voltage	施加在P和N之间 Between P and N	-	300	400	V
V_{CC}	控制电源电压 Control Supply Voltage	施加在 V_{CC} 和 COM之间 Between V_{CC} and COM	13.5	15.0	16.5	V
V_{BS}	高端偏压 High-Side Bias Voltage	施加在 V_B 和 V_S 之间 Between V_B and V_S	13.5	15.0	16.5	V
d_{VCC}/d_t d_{VBS}/d_t	控制电源波动 Control power fluctuation		-1	-	1	V/us
t_{dead}	防止桥臂直通的死区时间 Blanking Time for Preventing Arm-Short	$V_{CC} = V_{BS} = 13.5 \sim 16.5 \text{ V}, T_j \leq 150^\circ\text{C}$	1.0	-	-	us
F_{PWM}	PWM 开关频率 PWM Switching Frequency	$T_j \leq 150^\circ\text{C}$	-	-	20	KHz



图 3: 开关时间定义
Fig 3: Switching Time Definition



内部 NTC –热阻特性 Internal NTC-thermal resistance characteristics

记号 Mark	项目 Project	条件 Condition	最小值 Min.	典型值 Typ.	最大值 Max.	单位 Unit
R _{NTC}	热敏电阻 Thermistor	T _{NTC} = 25°C	97	100	103	Kohm
		T _{NTC} = 125°C	3.25	3.46	3.69	Kohm
温度范围 temperature range			-40	-	+125	°C

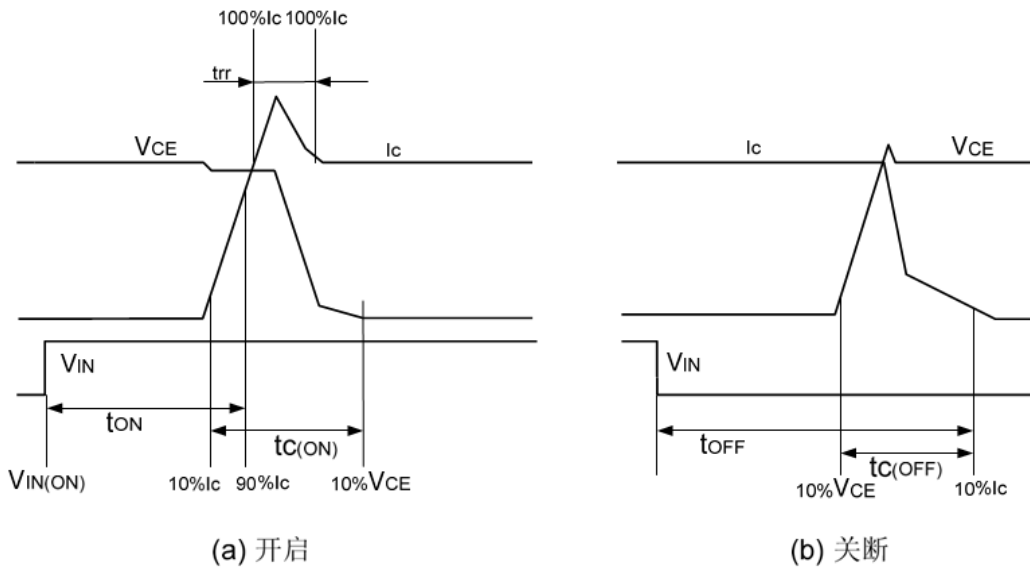
T(°C)	Rmin(kΩ)	Rnor(kΩ)	Rmax(kΩ)	T(°C)	Rmin(kΩ)	Rnor(kΩ)	Rmax(kΩ)
25	97.000	100.000	103.000	80	12.1509	12.7870	13.4443
30	78.201	80.792	83.393	85	10.3432	10.9021	11.4808
35	63.418	65.655	67.910	90	8.8389	9.3310	9.8416
40	51.721	53.654	55.608	95	7.5818	8.0160	8.4675
45	42.411	44.083	45.779	100	6.5271	6.9112	7.3113
50	34.960	36.407	37.880	105	5.6389	5.9793	6.3347
55	28.974	30.230	31.512	110	4.8880	5.1905	5.5067
60	24.1316	25.2230	26.3400	115	4.2510	4.5203	4.8024
65	20.1933	21.1438	22.1191	120	3.7087	3.9490	4.2011
70	16.9745	17.8042	18.6575	125	3.2455	3.4604	3.6861
75	14.3314	15.0570	15.8052				



图 4.1. NTC 电阻温度曲线及表

Fig 4.1: NTC Resistance temperature curve and table

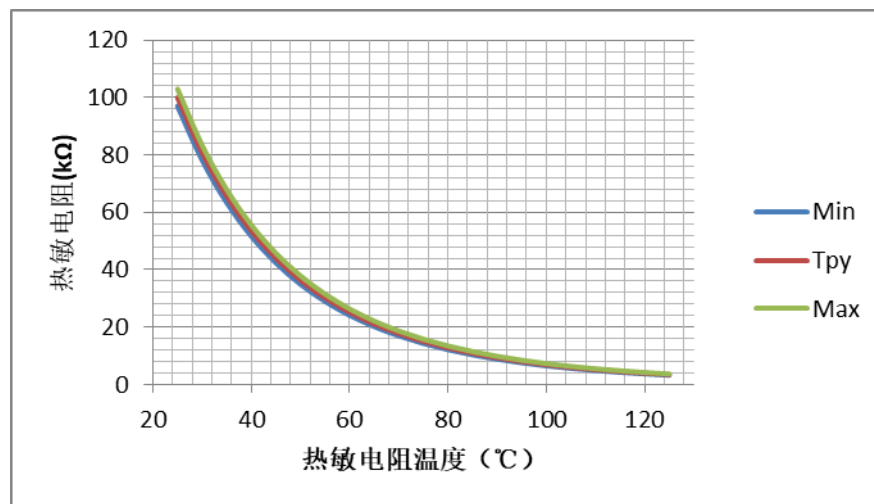

图 4.2: 温度检测输出温度—电压曲线 (上拉 6.8KΩ电阻至 5V, 上拉 4.7KΩ电阻至 3.3V)

Fig 4.2: Curves of Temperature detection-voltage curve (Pull up the 6.8 KΩ resistance to 5V, pull up the 4.7 KΩ resistance to 3.3V)

保护功能时序图 Time Charts of Protective Function

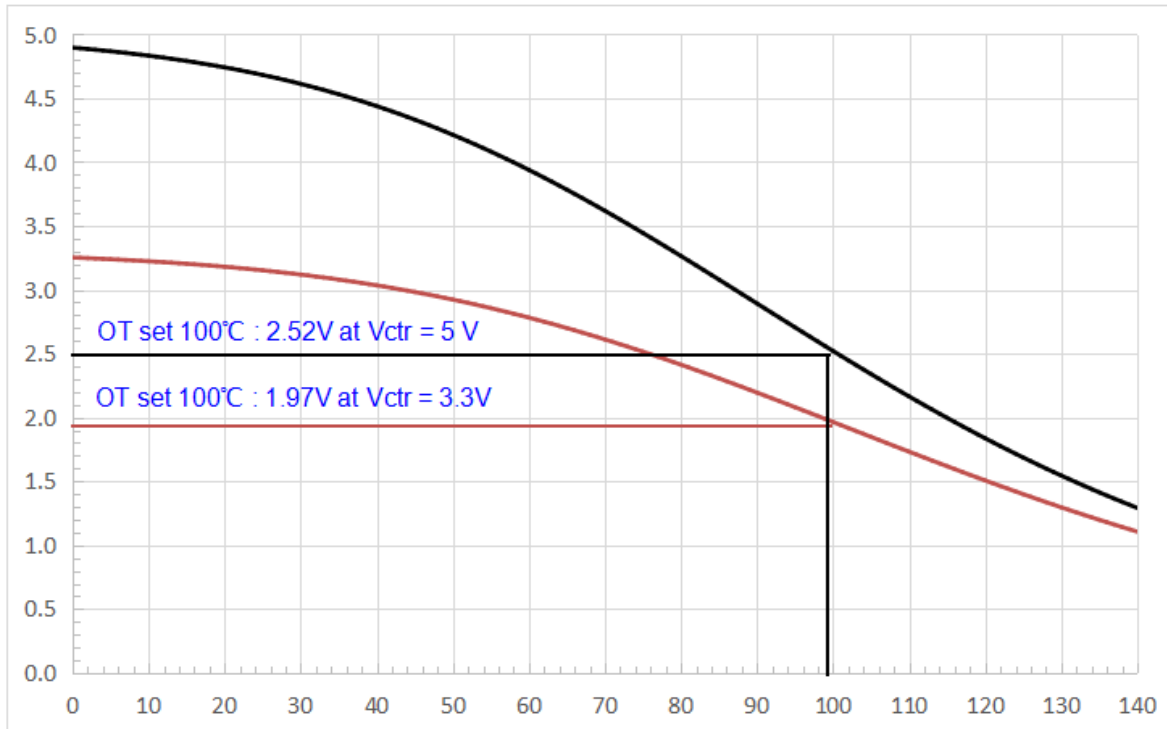

图 5: 欠压保护时序图(低侧)

Fig 5: Undervoltage protection sequence diagram (low side)

- a1: 电源电压上升: 电压上升至 UV_{CCR} , 当下一个输入信号到来时电路开始工作;
a1: Control supply voltage rises: after the voltage rises UV_{CCR} , the circuits start to operate when next input is applied.
- a2: 正常运行: IGBT 开启并加载电流。
a2: Normal operation: IGBT turns on and loads current.
- a3: 欠压检测点(UV_{CCD})。
a3: Undervoltage detection point (UV_{CCD}).
- a4: 不管输入是什么信号, IGBT 都是关闭状态。
a4: No matter what signal is input, the IGBT is off.
- a5: 故障输出开启。
a5: Fault output is on.
- a6: 欠压恢复(UV_{CCR})。
a6: Undervoltage recovery (UV_{CCR}).
- a7: 正常运行: IGBT 导通并加载负载电流。
a7: Normal operation: IGBT is turned on and load current is loaded.

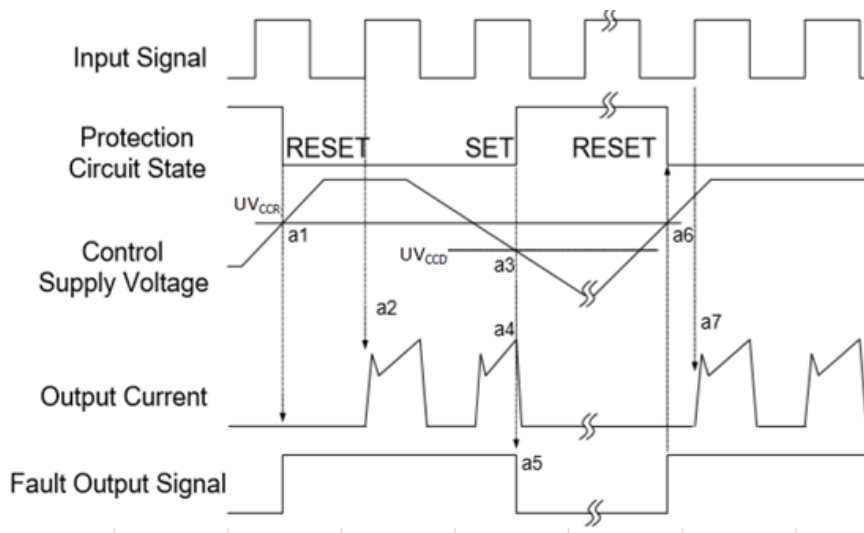

图 6: 欠压保护时序图(高侧)

Fig 6: Undervoltage protection sequence diagram (High side)

- b1: 电源电压上升: 当该电压上升到欠压恢复点, 在下一个欠压信号被执行前该线路将启动运行。
b1: Power supply voltage rise: When the voltage rises to the undervoltage recovery point, the line will start running before the next undervoltage signal is executed.
- b2: 正常运行: IGBT 导通并加载负载电流。
b2: Normal operation: IGBT is turned on and load current is applied.
- b3: 欠压检测 (UV_{BSD})。
b3: Undervoltage detection (UV_{BSD}).
- b4: 不管输入是什么信号, IGBT 都是关闭状态。
b4: No matter what signal is input, IGBT is off.

b5 : 欠压恢复(UV_{BSR})。

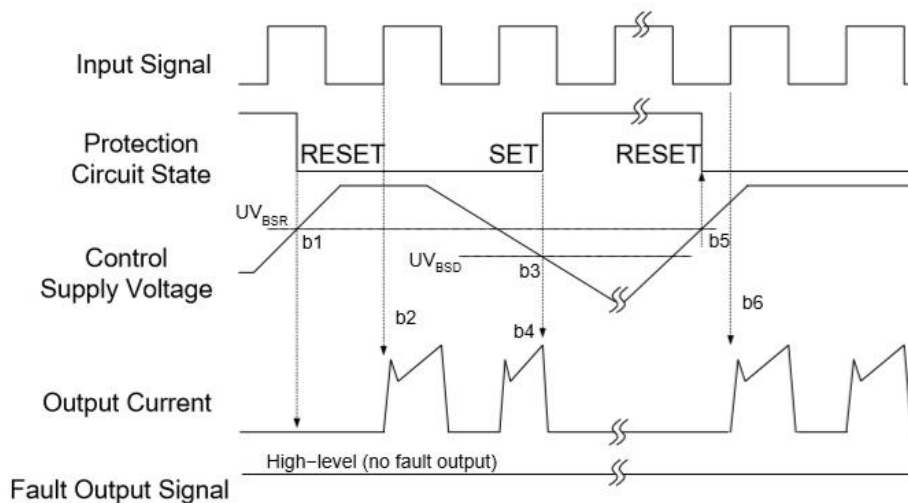
b5: Undervoltage recovery (UV_{BSR})。

b6 : 正常运行: IGBT 导通并加载负载电流。

b6: Normal operation: IGBT is turned on and load current is applied.



图 7: 过流保护时序

Fig 7: Fault-Out Function by Over Current Protection

HIN :高侧输入信号;

HIN : High-side Input Signal

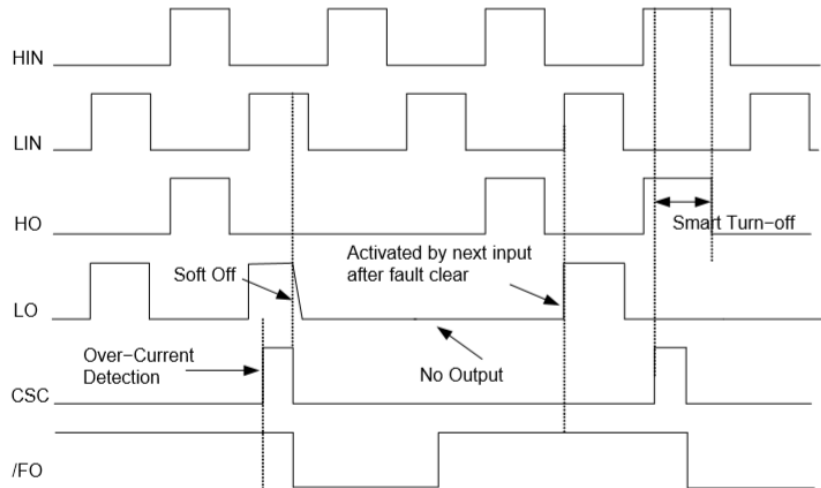
LIN : 低侧输入信号;

LIN : Low-side Input Signal

HO : 高侧输出信号;

HO : High-Side Output Signal

LO : 低侧输出信号;

LO : Low-Side Output Signal

CSC :过流侦测信号;

CSC : Over Current Detection Input

/FO:故障输出信号

/FO : Fault Out Function



图 8. 外部关断功能时序

Figure 8. Shutdown Input Function by External Command

HIN : 高侧输入信号;

HIN : High-side Input Signal

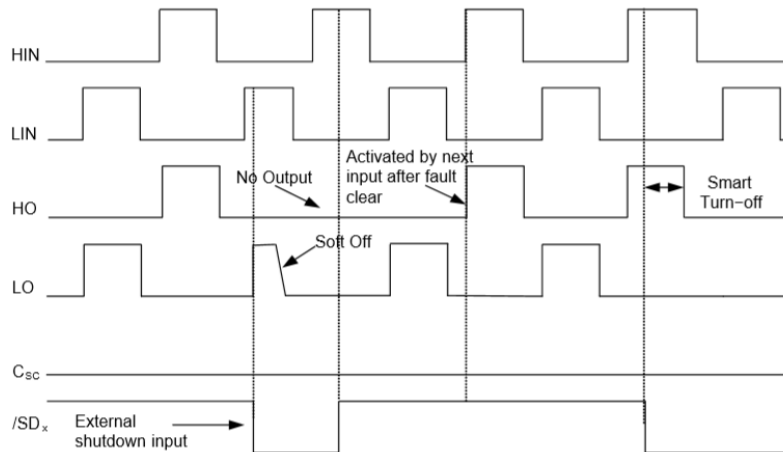
LIN : 低侧输入信号;

LIN : Low-side Input Signal

HO : 高侧输出信号;

HO : High-Side Output Signal

LO : 低侧输出信号;

LO : Low-Side Output Signal

CSC : 过流侦测信号;

CSC : Over Current Detection Input

/SDx: 外部关断输入信号

/SDx : Shutdown Input Function

输入输出接口电路 Input/output interface circuit



图 9. 推荐的 MCU I/O 接口电路

Figure 9: Recommended MCU input and output interface circuit

备注 5: 由于 PWM 的控制方式和实际应用电路的阻抗及线路板的阻抗, RC 去耦可能会有变化。

Note 5 : Due to the PWM control method and the impedance of the actual application circuit and the impedance of the circuit board, RC decoupling may change.

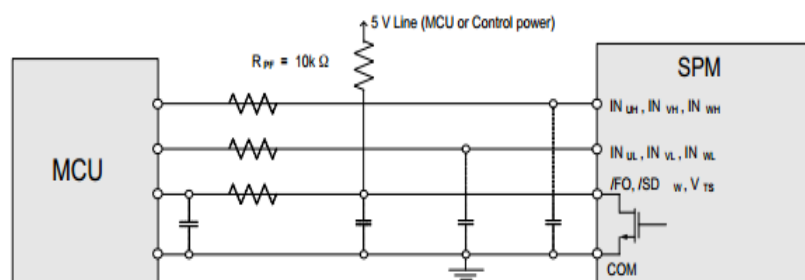
应用电路 Application Circuit



图 10: 典型应用电路图

Fig 10: Example of Application Circuit

备注 6: .关于引脚的位置请参阅图 1.

Note 6: Refer to figure 1 for pin location.

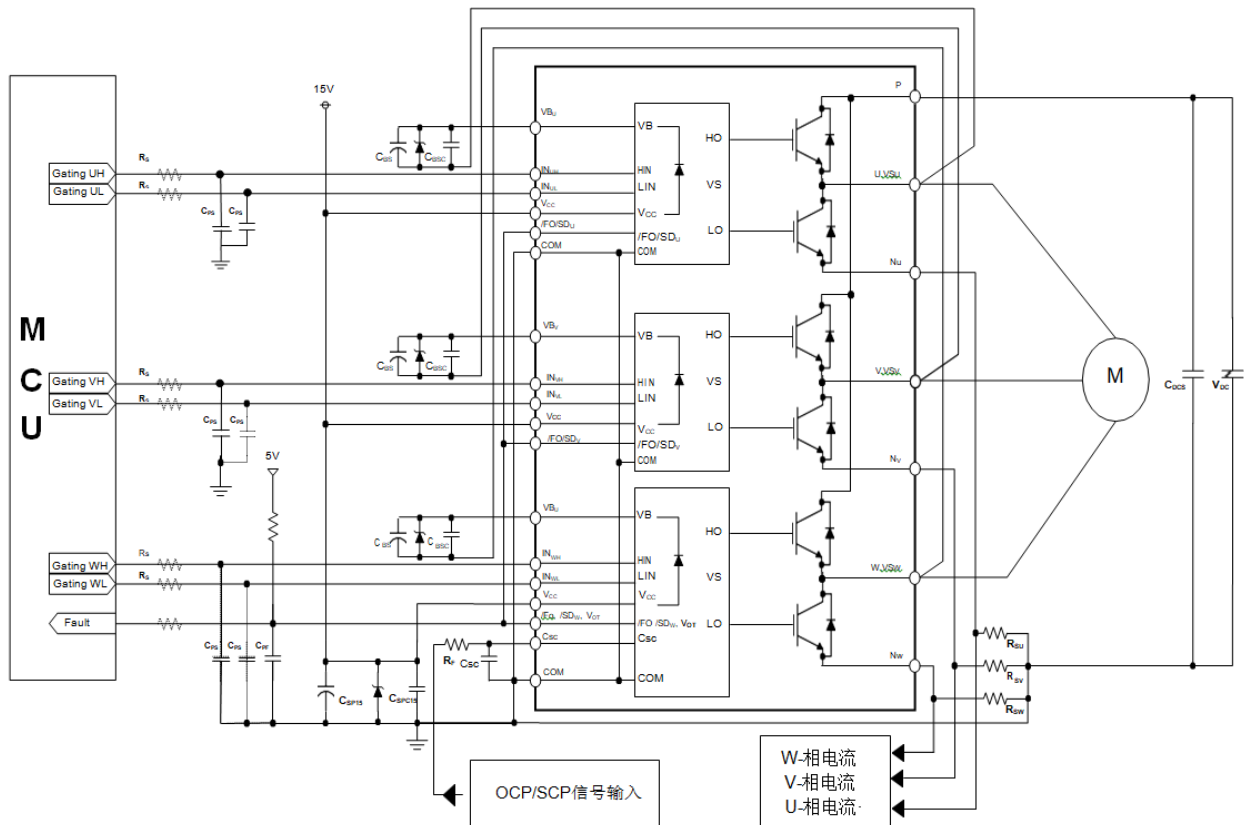
备注 7:为避免故障, 各输入接线应尽可能短。

Note 7:To avoid malfunction, the wiring of each input should be as short as possible

备注 8:为防止浪涌损坏, PN 之间建议增加一个高频非感性平复电容 (0.1 μ F~0.22 μ F), 电容的连线要尽量短。

Note 8:To prevent surge destruction, it is recommended to add a high-frequency non inductive smoothing capacitor (0.1 μ F~0.22 μ F) between PN, and the wiring of the capacitor should be as short as possible.

备注 9:输入信号高电平有效, 在 HVIC 每个通道的输入端都有一个下拉电阻连接到地; 建议在输入端增加 RC 滤波电路来防止输入信号振荡。

Note 9: The high level of the input signal is effective, and a pull-down resistor is connected to the ground at the input terminals of each channel of HVIC; It is suggested to add RC filter circuit at the input terminals to prevent input signal oscillation.

备注 10:所有电容的位置尽可能的靠近 IPM。

Note 10: Position all capacitors as close to IPM as possible.

备注 11:控制地线和电源地线要连接在一个点, 走线尽量短;



Note 11: The control ground wire and power ground wire shall be connected at one point, and the wiring shall be as short as possible;

备注 12.在短路保护电路, 请选择时间常数在 1.5~2us 范围内的 RF 和 CSC,同时 RF 和 CSC 周边的接线都应尽量短, RF 接线应靠近分流电阻;

Note 12: In the short-circuit current protection circuit, please select the RF CSC time constant in the range 1.5~2us, At the same time, the wiring around RF and CSC shall be as short as possible, and RF wiring shall be close to shunt resistance;

备注 13./FO,/SD 的连线尽可能短。

Note 13:/FO and /SD must be connected as short as possible.



外形封装图 Detailed Package Outline Drawings



图 11: SPE10S60H-A 封装外形图

Fig 11: SPE10S60H-A Package Outline Drawings

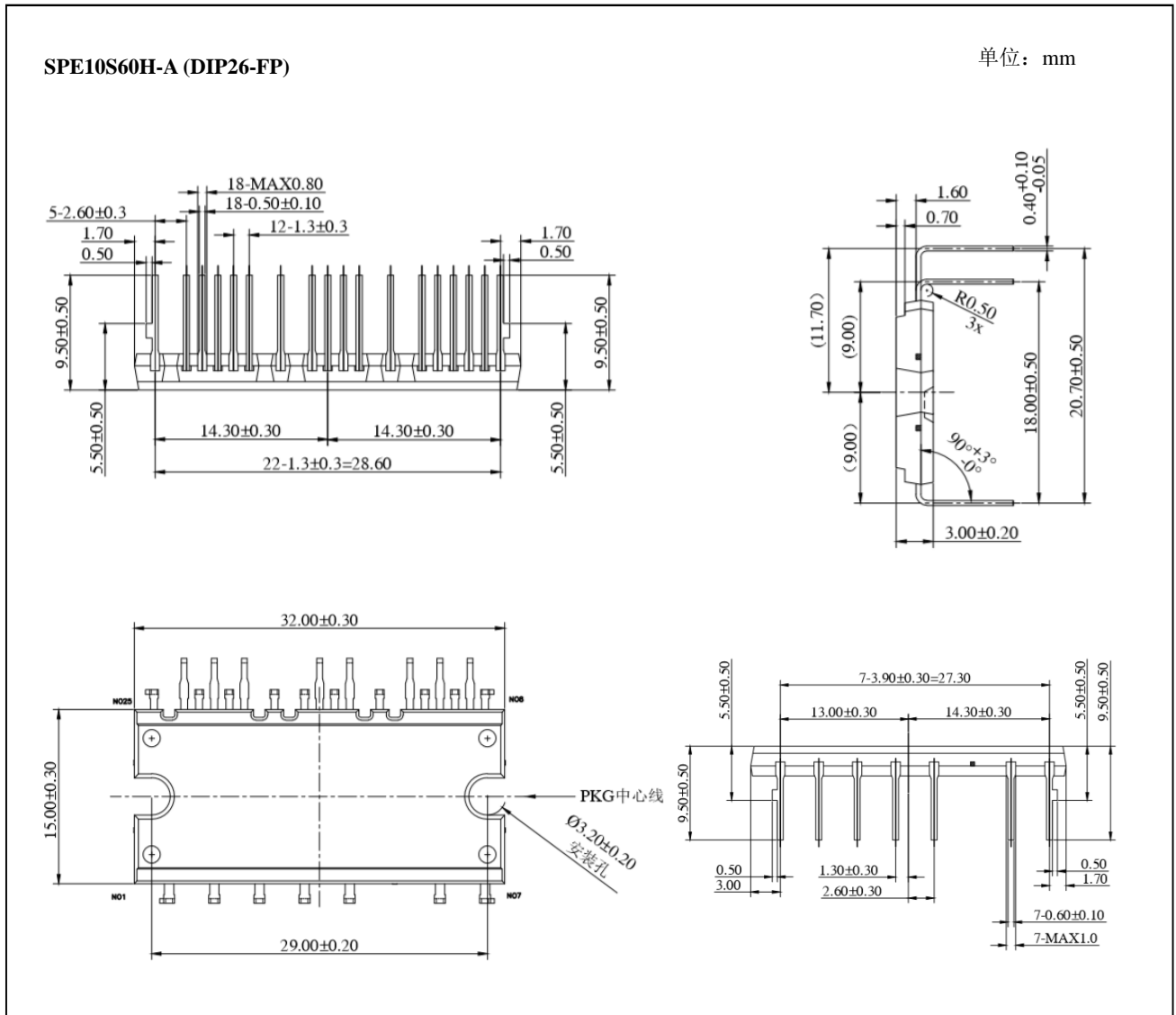

注意事项

1. 吉林华微电子股份有限公司的产品销售分为直销和销售代理，无论哪种方式，订货时请与公司核实。
2. 购买时请认清公司商标，如有疑问请与公司本部联系。
3. 在电路设计时请不要超过器件的绝对最大额定值，否则会影响整机的可靠性。
4. 本说明书如有版本变更不另外告知。

NOTE

1. Jilin Sino-microelectronics co., Ltd sales its product either through direct sales or sales agent , thus, for customers, when ordering , please check with our company.
2. We strongly recommend customers check carefully on the trademark when buying our product, if there is any question, please don't be hesitate to contact us.
3. Please do not exceed the absolute maximum ratings of the device when circuit designing.
4. Jilin Sino-microelectronics co., Ltd reserves the right to make changes in this. specification sheet and is subject to change without prior notice.

联系方式

吉林华微电子股份有限公司

公司地址：吉林省吉林市深圳街 99 号

邮编：132013

总机：86-432-64678411

传真：86-432-64665812

网址：www.hwdz.com.cn

CONTACT

JILIN SINO-MICROELECTRONICS CO., LTD.

ADD: No.99 Shenzhen Street, Jilin City, Jilin Province, China.

Post Code: 132013

Tel: 86-432-64678411

Fax: 86-432-64665812

Web Site: www.hwdz.com.cn